

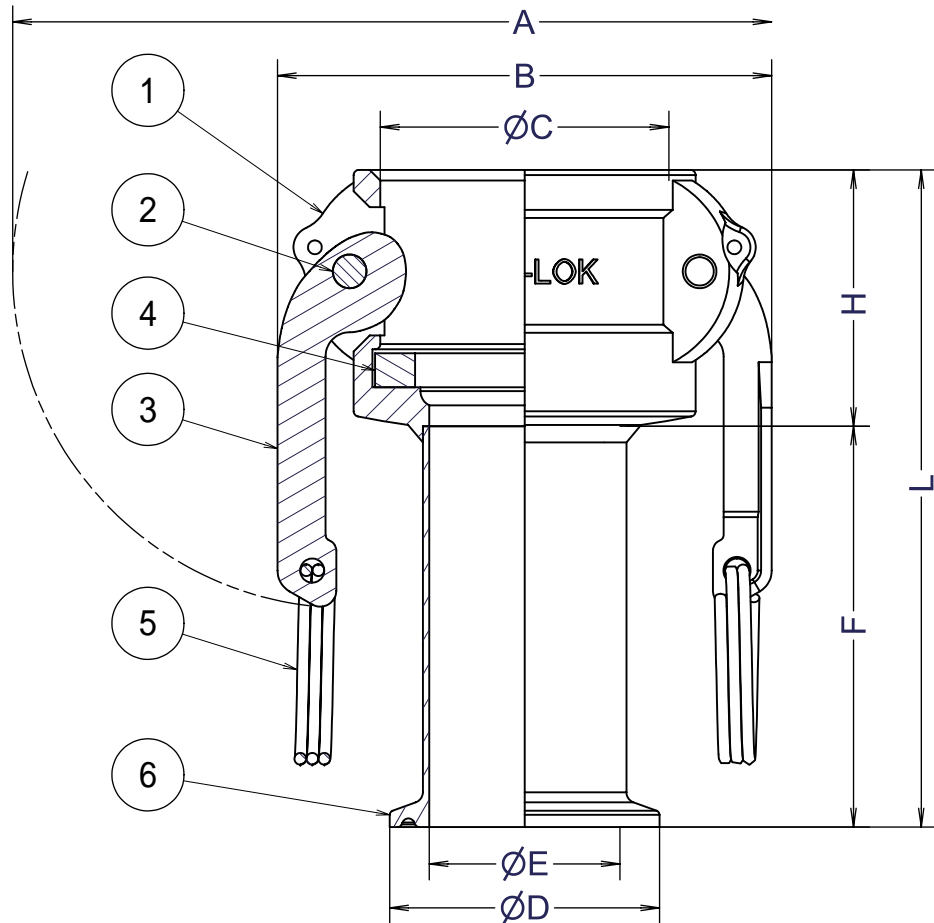

Item No.		SC-3/4"x1S	SC-1"x1S	SC-11/4"x1.5S	SC-11/2"x1.5S	SC-2"x2S	SC-21/2"x2.5S	SC-3"x3S	SC-4"x4S
Size	mm	20	25	32	40	50	65	80	100
	inches	3/4	1	1 1/4	1 1/2	2	2 1/2	3	4
A		116	136	183	191	201	213	266	294
B		54	61	85	92	102	114	138	166
∅C		32.4	37.2	46	54	63.8	76.5	92.2	120.2
∅D		50.5	50.5	50.5	50.5	64	77.5	91	119
∅E		23	23	35.7	35.7	47.8	59.5	72.3	97.6
F		55	60	75	75	75	80	90	90
H		33	40.5	47.5	48	55	58	59	63
L		88	100.5	122.5	123	130	138	149	153

Units:mm



6	ロングヘルール	SUS316 SUS304	1	
5	リング	SUS304	2	
4	ガスケット	NBR	1	
3	カムアーム	SCS16A	2	
2	ピン	SUS304	2	
1	ボディ	SCS14A	1	
ITEM	PART NAME	MATERIAL	Q'TY	REMARKS

Nominal Dia	CUSTOMER				TITLE	
Fluid.					MAX-LOK MAX-SC サニタリーカップラ-	
Press.						
Temp.	DATE	SCALE	DRAW	APPR	 FULLNESS JAPAN CORPORATION.	
Drawing History	Aug.31'18	none	ToMo			
	DWG No.					
	MAX-SC-04SS-82			3		