

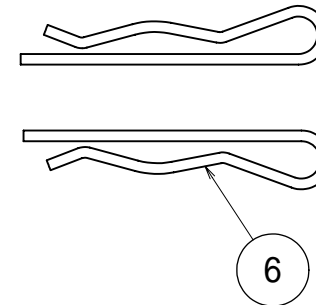

Item No.	75x50-D	75-D	100-D	125-D	150-D	200-D	250-D	300-D	400-D	
Size	mm	20x15	20	25	32	40	50	65	80	100
	inches	3/4x1/2	3/4	1	1 1/4	1 1/2	2	2 1/2	3	4
A		116	116	136	183	191	201	213	266	294
B		54	54	61	85	92	102	114	138	166
ØC		32.4	32.4	37.2	46	54	63.8	76.5	92.2	120.2
ØF		16	19	26	34	39	49	59	74.5	94
K		27	32	40	48	56	67	83	97	125
H		32	32	39	46	46	53	56	57	61
L		49	52	60	66	68	78	86	89	98
Weight(kg)		0.21	0.22	0.33	0.59	0.66	0.91	1.30	1.65	2.59

Units:mm

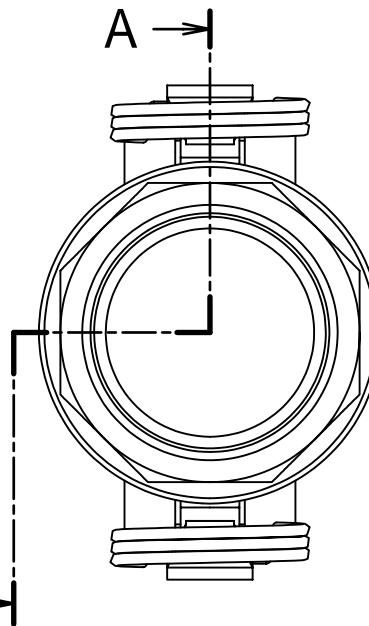
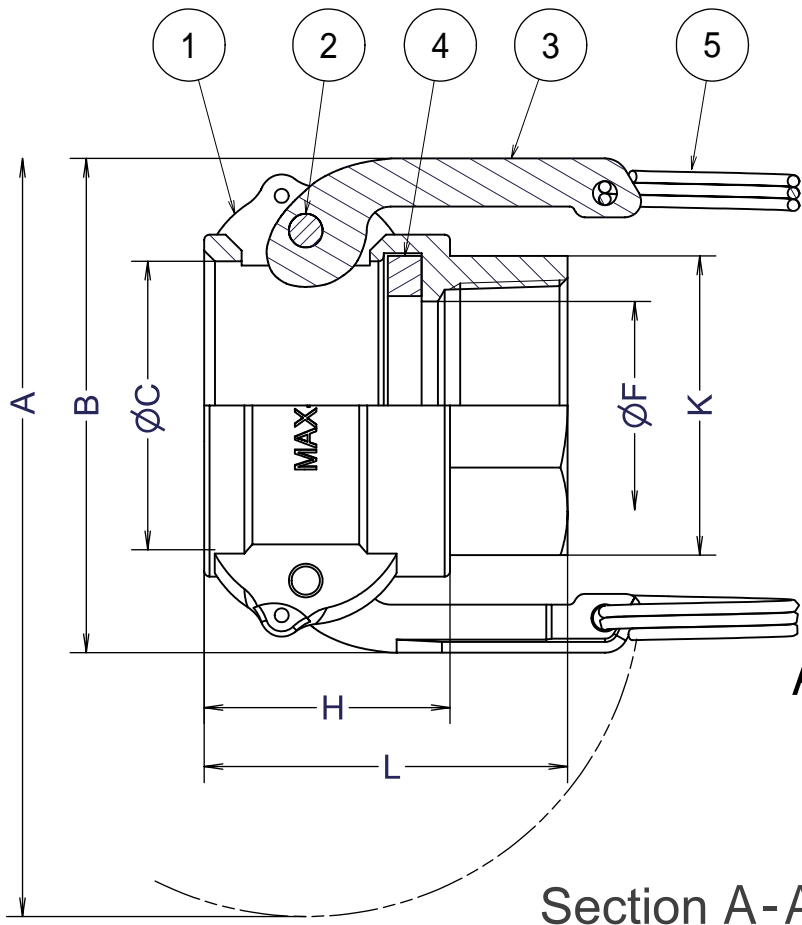

6	セーフティピン	SUS304	2	
5	リング	SUS304	2	
4	ガスケット	NBR	1	
3	カムアーム	SCS16A	2	
2	ピン	SUS304	2	
1	ボディ	SCS14A	1	
ITEM	PART NAME	MATERIAL	Q'TY	REMARKS

Nominal Dia	CUSTOMER				TITLE	
Fluid.					<b>MAX-LOK</b> MAX-D 雌ネジカプラー	
Press.						
Temp.					 <b>FULLNESS JAPAN CORPORATION.</b>	
Drawing History						
	DATE	SCALE	DRAW	APPR		
	Sep.4'18	none	ToMo			
	DWG No.					
	MAX-D-04SS-84			3		