

Part No.	75x50-E	75-E	100-E	125-E	150-E	200-E	300-E	400-E	
Size	mm	20x15	20	25	32	40	50	80	100
	inches	3/4x1/2	3/4	1	1 1/4	1 1/2	2	3	4
ØD			32	36.7		53.4	63		
ØF			14	19		30	41		
ØG			20.6	26.4		39.6	52.4		
H			27	34		42	47.5		
I			54	58		72	83		
L			93	107		132	150.5		

Units:mm

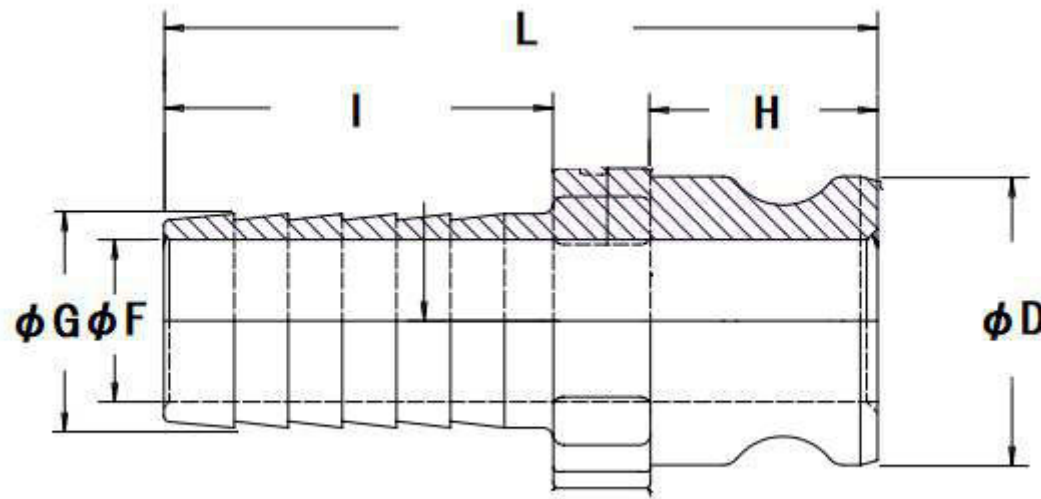

Section B-B

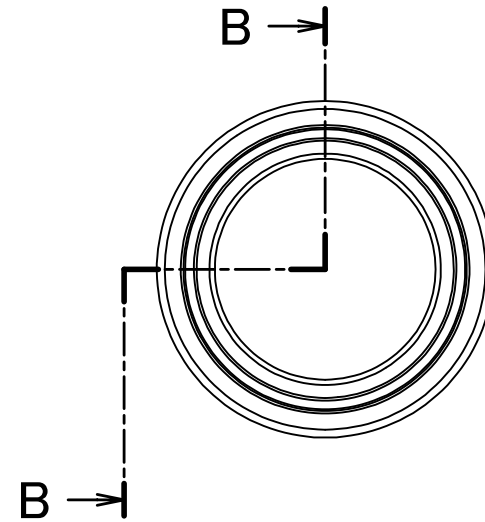

Nominal Dia	
Fluid.	
Press.	
Temp.	
Drawing History	

1	BODY	ポリプロピレン	1	
ITEM	PART NAME	MATERIAL	Q'TY	REMARKS
CUSTOMER		TITLE		
		MAX-E-MB		
		ホースシャンクアダプター		
DATE		SCALE	DRAW	APPR
		none		
DWG No.		3		
MAX-E-MB-05PP-N01		 <b>FULLNESS JAPAN CORPORATION.</b>		