

Part No.	75x50-D	75-D	100-D	125-D	150-D	200-D	300-D	400-D	
Size	mm	20x15	20	25	32	40	50	80	100
	inches	3/4x1/2	3/4	1	1 1/4	1 1/2	2	3	4
A		114	110	125	177	185	195	249	279
B		66	56	62	82	90	100	135	166
ØC		33	33	37.5	47	55	64.5	93	120
ØF		16.5	22	26	35	41	50	76	102
H		32	32	41	44	50	57	60	58
L		50	50	61	64	78	84	90	91

Units:mm

注意  
400-Dのカムアームは4本です。

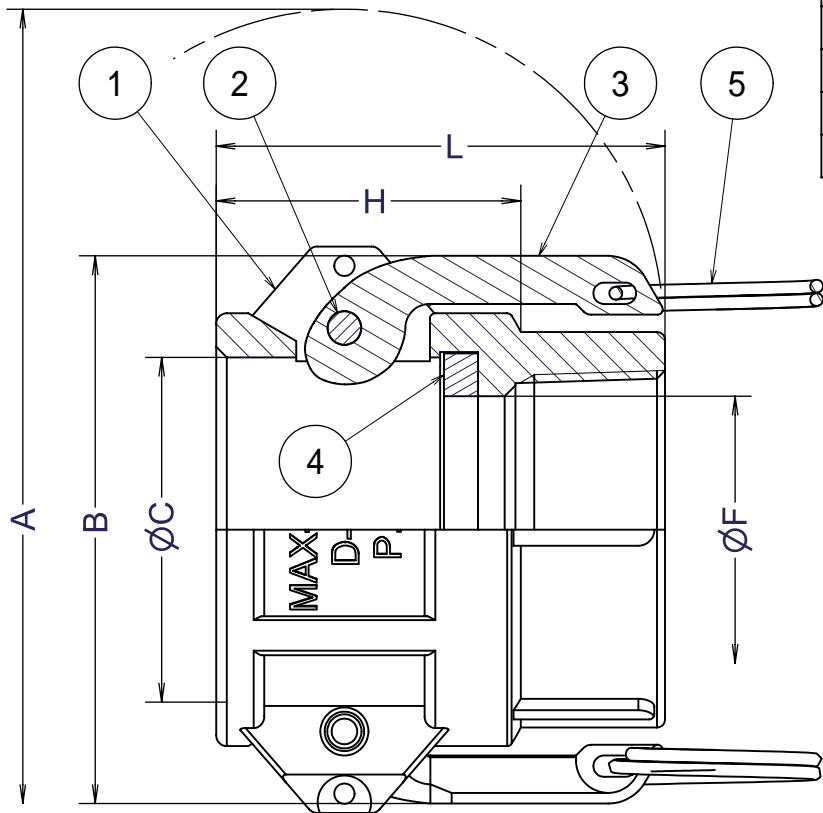

Section B-B

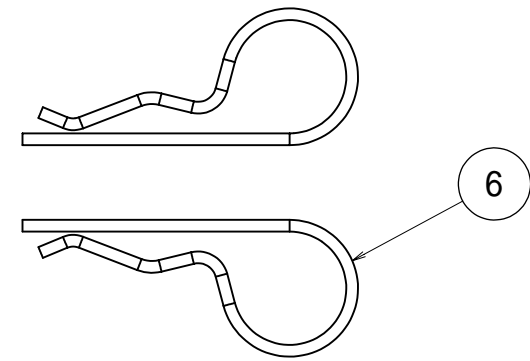
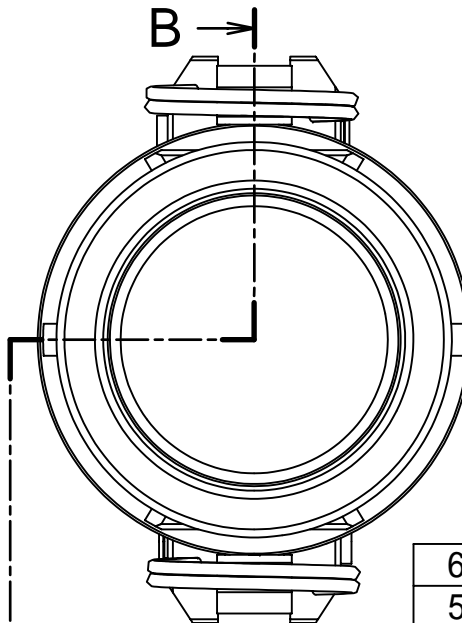

6	セーフティピン	SWRH77B	2	
5	リング	SUS430	2	
4	ガスケット	NBR	1	
3	カムアーム	SUS430	2	
2	ピン	SUS430	2	
1	ボディ	ポリプロピレン	1	
ITEM	PART NAME	MATERIAL	Q'TY	REMARKS

Nominal Dia	CUSTOMER				TITLE
Fluid.					<b>MAX-LOK</b> MAX-D 雌ネジカプラ-
Press.	DATE	SCALE	DRAW	APPR	
Temp.	Mar.5'13	none	ToMo		 <b>FULLNESS JAPAN CORPORATION.</b>
Drawing History	MAX-D-05PP-33			3	