

Part No.	75x50-C	75-C	100-C	125-C	150-C	200-C	300-C	400-C	
Size	mm	20x15	20	25	32	40	50	80	100
	inches	3/4x1/2	3/4	1	1 1/4	1 1/2	2	3	4
A									
B									
ØC		32.4	32.4	37.2	46	54.4	64		
ØF		8	14	19	23	30	40		
ØG		14	20.6	26.4	32.8	39.6	52.4		
I		42	54	58	67	72	83		
L		77	89	101	115	121	140		

Units:mm

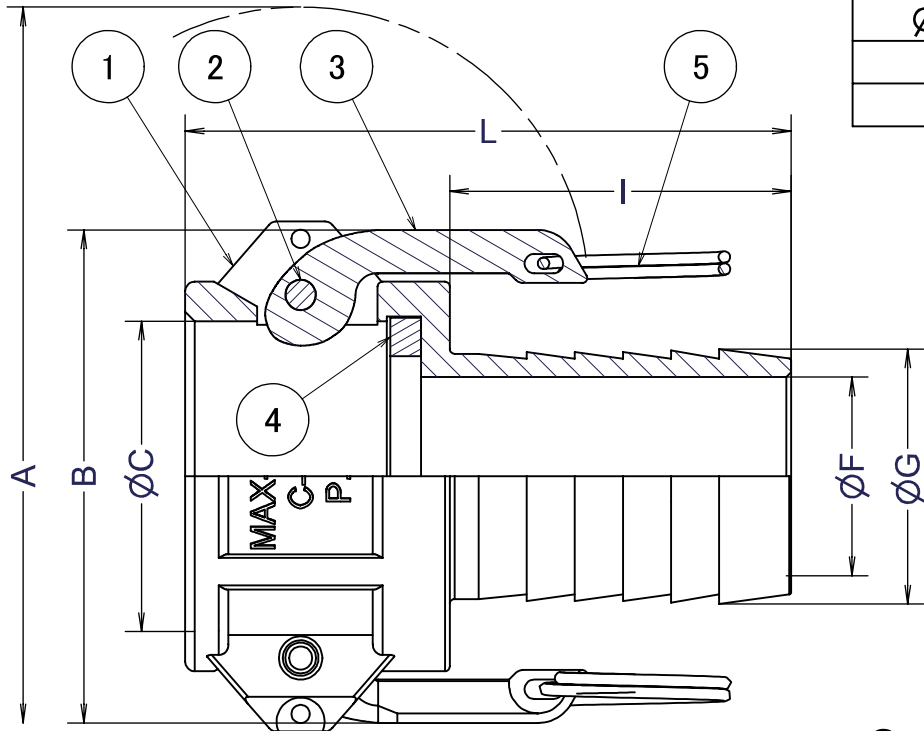

Section C-C

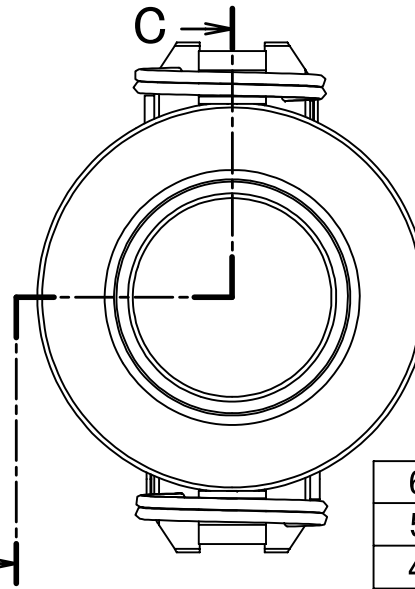

6	セーフティピン	SUS304	2	
5	リング	SUS304	2	
4	ガスケット	NBR	1	
3	カムアーム	SUS304	2	
2	ピン	SUS304	2	
1	ボディ	ポリプロピレン	1	
ITEM	PART NAME	MATERIAL	Q'TY	REMARKS

Nominal Dia	
Fluid.	
Press.	
Temp.	
Drawing History	

CUSTOMER			
DATE	SCALE	DRAW	APPR
	none		
DWG No.			3
MAX-C-MB-05PP-N01			

TITLE

MAX-C-MB
ホースシャンクカップラー



FULLNESS JAPAN CORPORATION.