

Part No.	75x50-C	75-C	100-C	125-C	150-C	200-C	300-C	400-C	
Size	mm	20x15	20	25	32	40	50	80	100
	inches	3/4x1/2	3/4	1	1 1/4	1 1/2	2	3	4
A		110	110	125	177	185	195	249	279
B		56	56	62	82	90	100	135	166
ØC		33	33	37.5	47	55	64.5	93	120
ØF		8	14	20	25	30	41	65	89
ØG		14	20.5	27	32.5	39	52.5	77	104
I		40	52.5	57	61	61	71	102	108
L		72	84.5	98	106	111	126	161	166

Units:mm

注意
400-Cのカムアームは4本です。
300-C,400-Cはリブ式です。

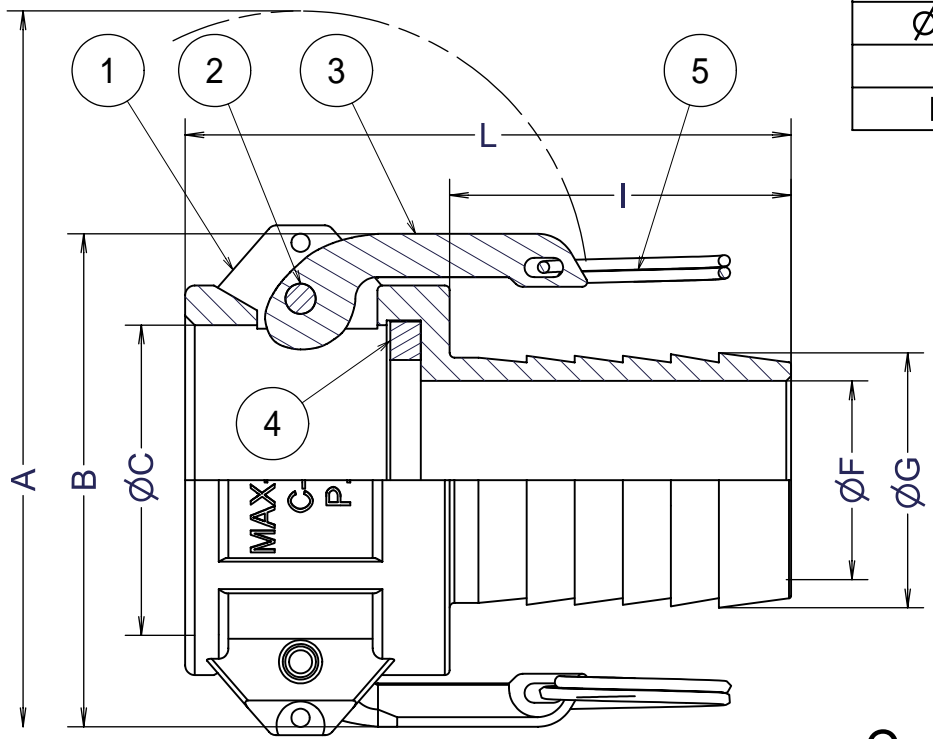

Section C-C

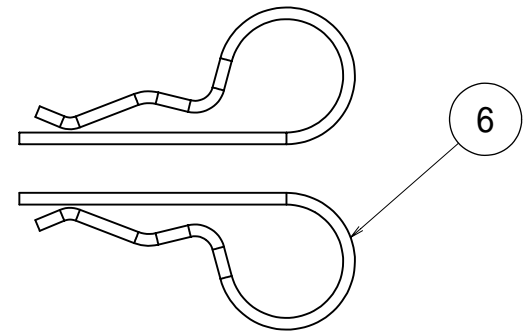
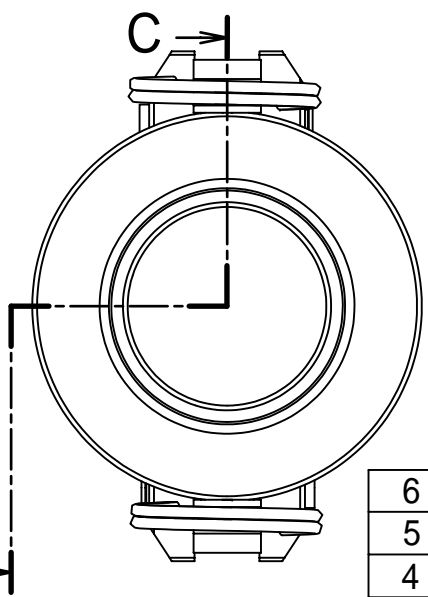

6	セーフティピン	SWRH77B	2	
5	リング	SUS430	2	
4	ガスケット	NBR	1	
3	カムアーム	SUS430	2	
2	ピン	SUS430	2	
1	ボディ	ポリプロピレン	1	
ITEM	PART NAME	MATERIAL	Q'TY	REMARKS

Nominal Dia	CUSTOMER				TITLE
Fluid.					MAX-LOK
Press.					
Temp.	DATE	SCALE	DRAW	APPR	MAX-C ホースシャックカブラ-
Drawing History	Mar.5'13	none	ToMo		 FULLNESS JAPAN CORPORATION.
	DWG No. MAX-C-05PP-33			3	