

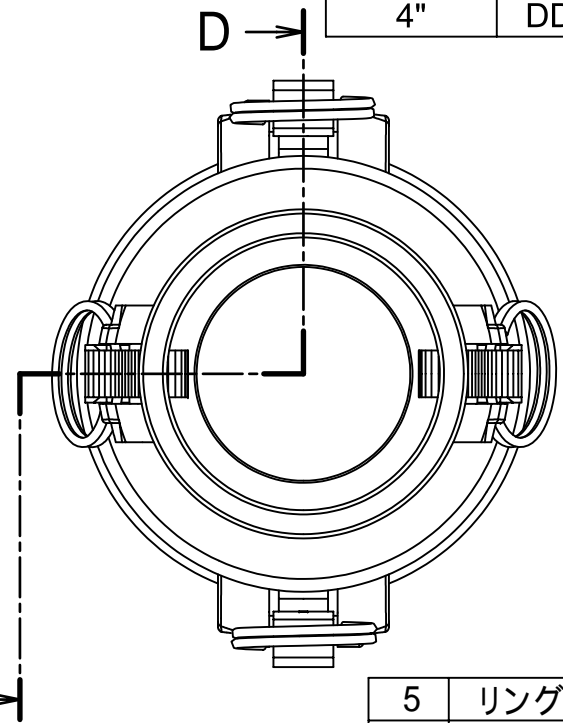

Section D-D

SIZE	PART No.	ϕC_1	ϕC_2	L
1 1/2"	DD150-AL	54	54	132
2"	DD200-AL	63.8	63.8	139
3"	DD300-AL	92.2	92.2	152
3" x 2"	DD30/20-AL	63.8	92.2	153
3" x 4"	DD30/40-AL	92.2	120.2	159
4" x 1 1/2"	DD40/15-AL	54	120.2	
4"	DD400-AL	120.2	120.2	157

Units:mm



5	リング	SUS304	4	
4	ガスケット	NBR	2	
3	カムアーム	BRASS	4	
2	ピン	SUS304	4	
1	ボディ	AC4C-T6	1	
ITEM	PART NAME	MATERIAL	Q'TY	REMARKS

Nominal Dia	CUSTOMER				TITLE	
Fluid.					MAX-LOK MAX-DD カプラ- X カプラ-	
Press.						
Temp.	DATE	SCALE	DRAW	APPR	 FULLNESS JAPAN CORPORATION.	
Drawing History	Jan.17'11	none	ToMo			
		DWG No.		MAX-DD-01AL-18		3