

Part No.	50-D	75x50-D	75-D	
Size	mm	15	20x15	20
	inches	1/2	3/4x1/2	3/4
A	109	116	116	
B	46	54	54	
ØC	24.4	32.5	32.5	
ØF	12	12	21	
K	26.7	31	31	
H	30	31.5	31.5	
L	44	46	46	
Weight(kg)	0.17	0.25	0.18	

Units:mm

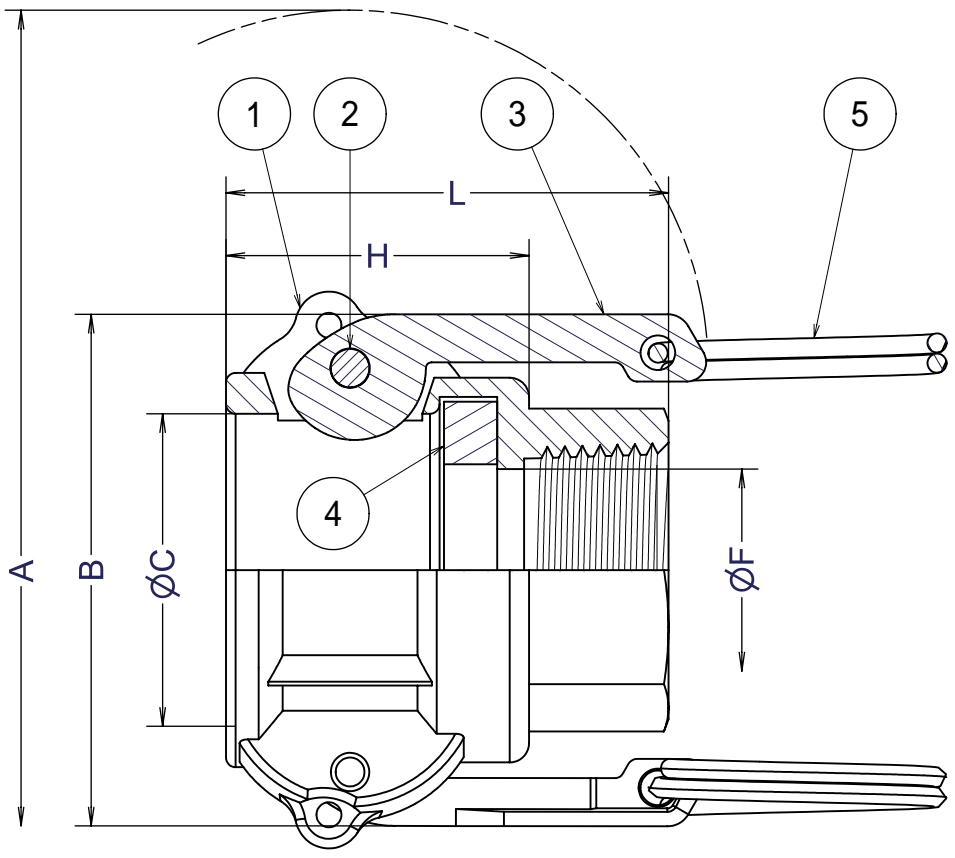

Section C-C

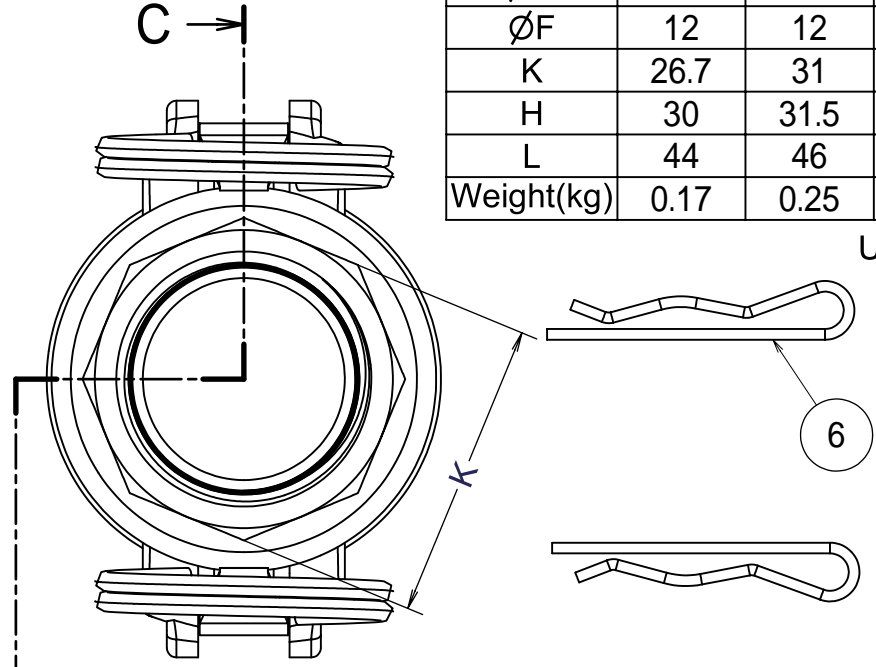

6	セーフティピン	SUS304	2	
5	リング	SUS304	2	
4	ガスケット	NBR	1	
3	カムアーム	SUS304	2	
2	ピン	SUS304	2	
1	ボディ	BRASS	1	
ITEM	PART NAME	MATERIAL	Q'TY	REMARKS

Nominal Dia	CUSTOMER				TITLE
Fluid.					<b>SFI</b> <sup>USA</sup> <i>Coupling.mini</i> <b>SFI-D 雌ネジカップラ-</b>
Press.	DATE	SCALE	DRAW	APPR	
Temp.	Nov.24'10	none	ToMo		 <b>FULLNESS JAPAN</b> <b>CORPORATION.</b>
Drawing History	SFI-D-03BS-MIN			3	