

Part No.	75x50-D	75-D	100-D	125-D	150-D	200-D	250-D	300-D	400-D	
Size	mm	20x15	20	25	32	40	50	65	80	100
	inches	3/4x1/2	3/4	1	1 1/4	1 1/2	2	2 1/2	3	4
A		116	116	126	179	186	196	208	251	280
B		54	54	61	84	91	101	113	138	166
ØC		32.4	32.4	37.2	46	54	63.8	76.5	92.2	120.2
ØF		12	21	26	34	39	49	59	74.5	101
K		31	31	40	48	56	67	80	93	121
H		31.5	31.5	39	46	46	53	53.5	55	55
L		46	46	59	66	66	78	82.5	86	90
Weight(kg)		0.25	0.18	0.34	0.6	0.7	0.9	0.85	1.2	1.77

Units:mm

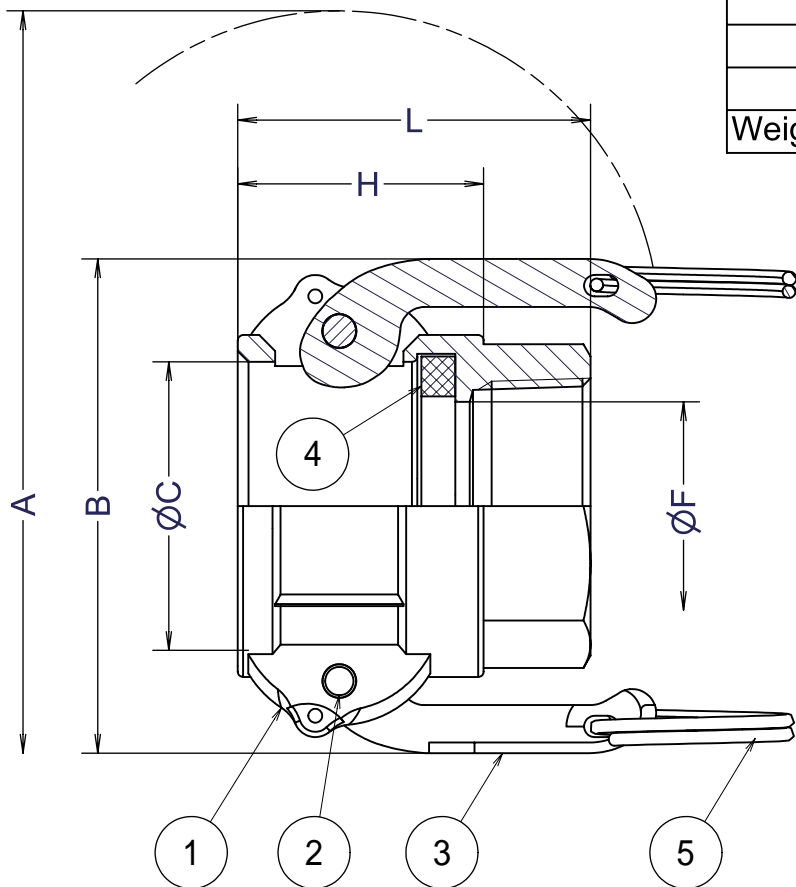

Section B-B

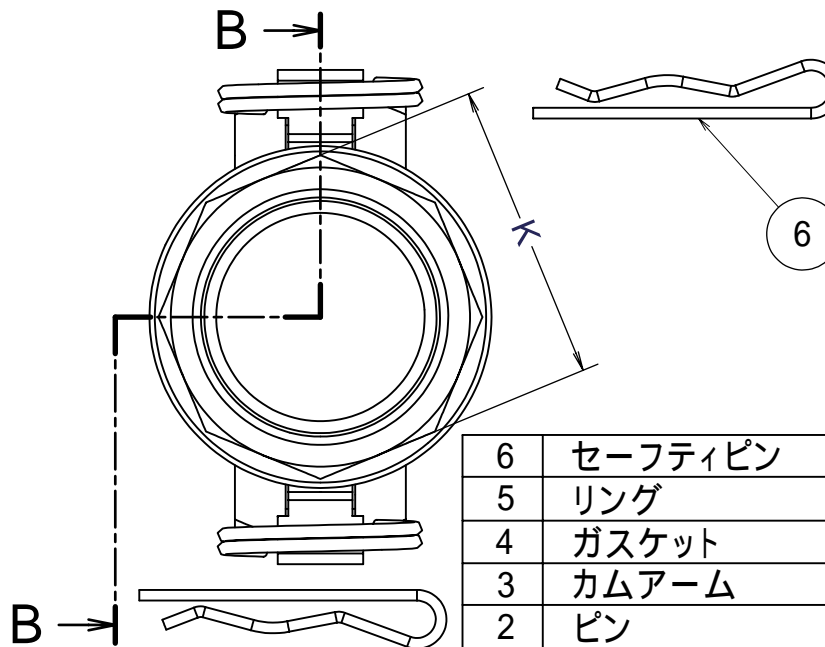

ITEM	PART NAME	MATERIAL	Q'TY	REMARKS
6	セーフティピン	SUS304	2	
5	リング	SUS304	2	
4	ガスケット	NBR	1	
3	カムアーム	SUS304	2	
2	ピン	SUS304	2	
1	ボディ	BRASS	1	

Nominal Dia	CUSTOMER				TITLE
Fluid.					<b>SFI</b> <sup>USA</sup> <i>Coupling</i> <b>SFI-D 雌ネジカプラ</b>
Press.	DATE	SCALE	DRAW	APPR	
Temp.	Nov.10'09	none	ToMo		 <b>FULLNESS JAPAN</b> <b>CORPORATION.</b>
Drawing History	SFI-D-03BS-92			3	