

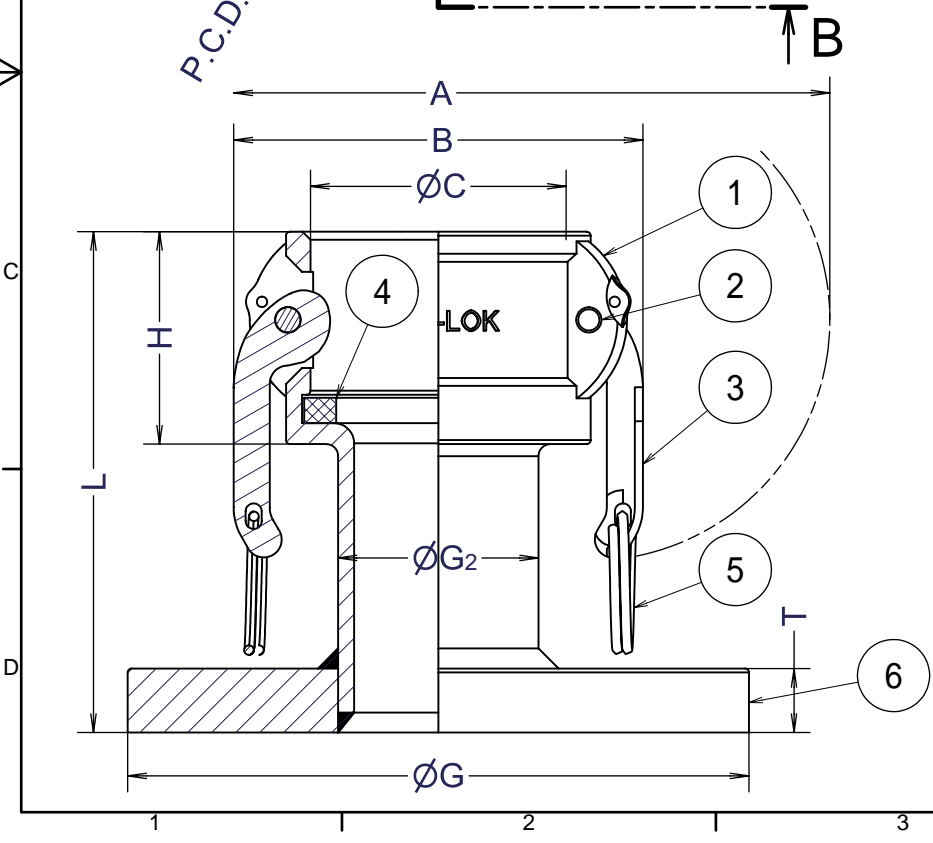

| Part No. | 75x50-FC | 75-FC | 100-FC | 125-FC | 150-FC | 200-FC | 250-FC | 300-FC | 400-FC | |
|-----------------|----------|---------|--------|--------|--------|--------|--------|--------|--------|-----|
| Size | mm | 20x15 | 20 | 25 | 32 | 40 | 50 | 65 | 80 | 100 |
| | inches | 3/4x1/2 | 3/4 | 1 | 1 1/4 | 1 1/2 | 2 | 2 1/2 | 3 | 4 |
| A | 116 | 116 | 126 | 179 | 186 | 196 | 208 | 251 | 280 | |
| B | 54 | 54 | 61 | 84 | 91 | 101 | 113 | 138 | 166 | |
| ØC | 32.4 | 32.4 | 37.2 | 46 | 54 | 63.8 | 76.5 | 92.2 | 120.2 | |
| ØG ₂ | 12 | 19 | 25 | 31.8 | 37.7 | 50 | 63 | 74.5 | 100 | |
| P.C.D.ØF | 70 | 75 | 90 | 100 | 105 | 120 | 140 | 150 | 175 | |
| ØG | 95 | 100 | 125 | 135 | 140 | 155 | 175 | 185 | 210 | |
| n | 4 | 4 | 4 | 4 | 4 | 4 | 4 | 8 | 8 | |
| Øh | 15 | 15 | 19 | 19 | 19 | 19 | 19 | 19 | 19 | |
| T | 12 | 14 | 14 | 16 | 16 | 16 | 18 | 18 | 18 | |
| H | 32 | 32.5 | 39.5 | 46.5 | 46.5 | 54 | 56 | 57 | 61 | |
| L | 88 | 90 | 96 | 115 | 117 | 125 | 130 | 144 | 148 | |

Units:mm



Section B-B

| | | | | |
|------|------------|----------|------|---------|
| 6 | JIS10kフランジ | アルミニウム | 1 | |
| 5 | リング | SUS304 | 2 | |
| 4 | ガスケット | NBR | 1 | |
| 3 | カムアーム | SUS304 | 2 | |
| 2 | ピン | SUS304 | 2 | |
| 1 | ボディ | AC4D-T6 | 1 | |
| ITEM | PART NAME | MATERIAL | Q'TY | REMARKS |

| | | | | | |
|-----------------|-----------|---------|------|----------------|--|
| Nominal Dia | CUSTOMER | | | | TITLE |
| Fluid. | | | | | MAX-LOK MAX-FC フランジカバー |
| Press. | | | | | |
| Temp. | DATE | SCALE | DRAW | APPR |  FULLNESS JAPAN CORPORATION. |
| Drawing History | Aug.25'08 | none | ToMo | | |
| | | DWG No. | | MAX-FC-01AL-82 | 3 |