

Part No.	75x50-D	75-D	100-D	125-D	150-D	200-D	250-D	300-D	400-D	
Size	mm	20x15	20	25	32	40	50	65	80	100
	inches	3/4x1/2	3/4	1	1 1/4	1 1/2	2	2 1/2	3	4
A		116	116	126	179	186	196	208	251	280
B		54	54	61	84	91	101	113	138	166
ØC		32.4	32.4	37.2	46	54	63.8	76.5	92.2	120.2
ØF		16	19	26	34	40	50	58	75.5	94
K		27	32	40	48	56	67	83	97	124.5
H		32	32	39	46	46	53	56	57	61
L		49.5	52	59	66	66	77	86	89	98
Weight(kg)		0.1	0.11	0.15	0.29	0.31	0.37	0.54	0.7	1.01

Units:mm

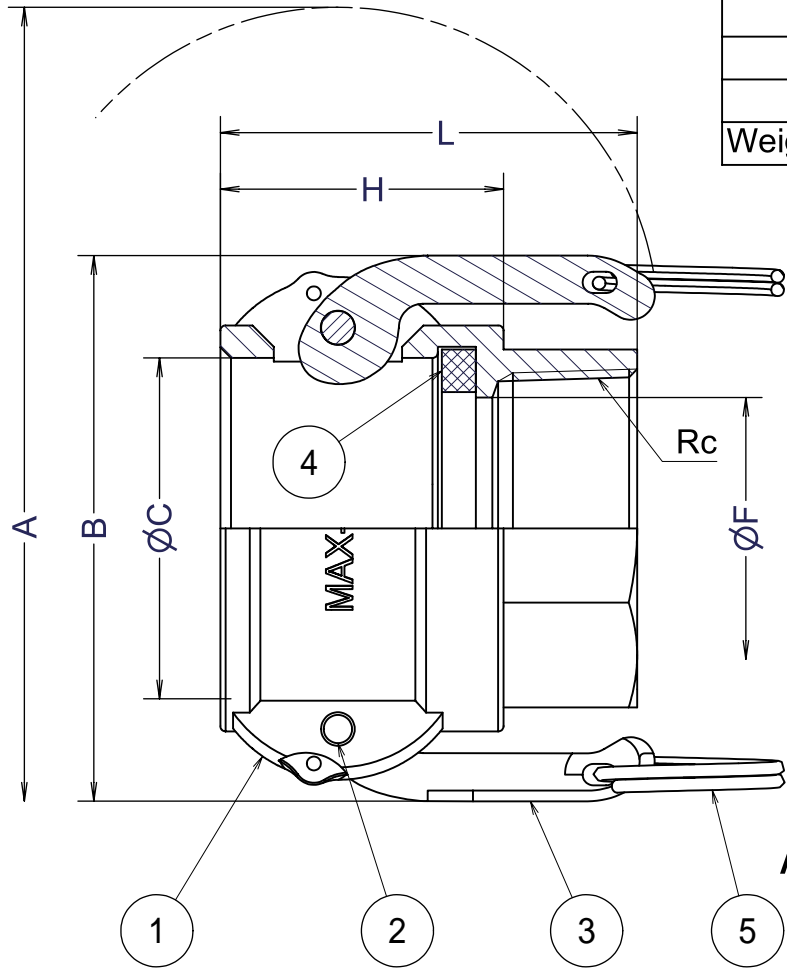

Section A-A

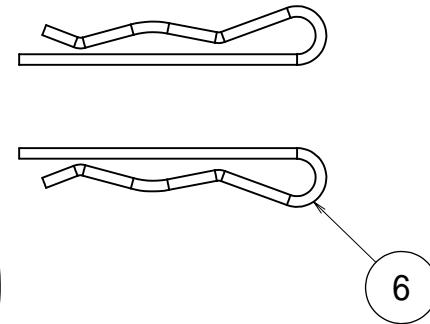
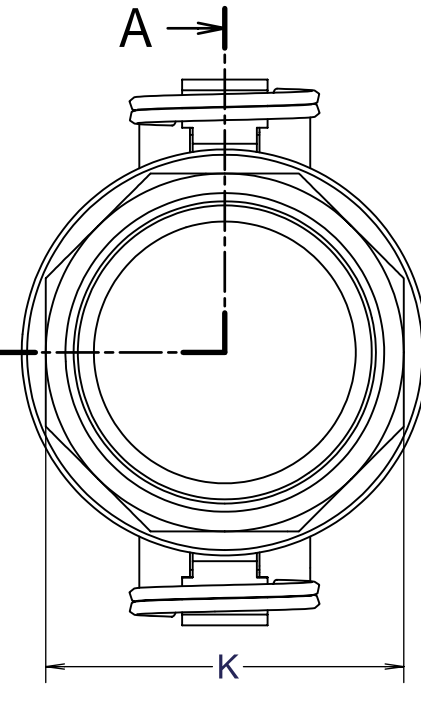

6	セーフティピン	SUS304	2	
5	リング	SUS304	2	
4	ガスケット	NBR	1	
3	カムアーム	SUS304	2	
2	ピン	SUS304	2	
1	ボディ	AC4C-T6	1	
ITEM	PART NAME	MATERIAL	Q'TY	REMARKS

Nominal Dia		CUSTOMER			
Fluid.		TITLE			
Press.		DATE	SCALE	DRAW	APPR
Temp.		Oct.27'09	none	ToMo	
Drawing History		DWG No. MAX-D-01AL-92			3

**MAX-LOK**  
MAX-D 雌ネジカプラ-

 FULLNESS JAPAN CORPORATION.